



Installation and Operation Guide For

MCF-49FD, MCF-23FD
MCR-49FD, MCR-23FD



CONTENTS

1. SPECIFICATIONS	2
2. SERIAL NUMBER	2
3. INSTALLATION	3
4. CLEANING	4
5. CAUTION	4
6. BASIC OPERATION	
6-1. REFRIGERATOR	5 - 6
6-2. FREEZER	7 - 8
7. REVERSIBLE DOOR ASSEMBLING METHOD	9 - 10
8. TROUBLE SHOOTING GUIDE	11

SPECIFICATIONS

Solid Door Refrigerators

MODEL	COMP. H.P	REFRIGERANT	AMPERAGE	POUNDS
MCR-23FD	1/3	R-134a	420W	271
MCR-49FD	1/2	R-134a	570W	370

Solid Door Freezers

MODEL	COMP. H.P	REFRIGERANT	AMPERAGE	POUNDS
MCF-23FD	1/3	R-134a	440W	284
MCF-49FD	1/2	R-404A	1340W	403

SERIAL NUMBER

The serial number is located on the rating label which is on the left interior wall. Please retain the unit's serial number for service purposes.

INSTALLATION

1. GOOD AIR CIRCULATION

- Be sure to avoid any object which will restrict exhausted air flow.
- Be sure that there is ample space so that air can flow through the rear of the unit.
- The back of the unit should be located no less than 5 inches from the wall.

2. PLACE ON STRONG GROUND

- Be sure the location chosen has a floor strong enough to support the total weight of the cabinet and contents.

3. DO NOT PLACE NEAR HEAT SOURCE

- Be sure to avoid hot corner or location near stove, oven, or other heat source.
- High ambient temperature will make cooling efficiency lower.

4. INDOOR USAGE ONLY

- This equipment is intended for indoor use only.

5. STABILIZING

- Make sure the unit is installed in a stable condition with the front wheels locked while in use.

6. LEVELING

- Be sure that the unit is level from front to back and side to side.

7. Unit should be on dedicated electrical circuit.

- Do not use extension cords
- Isolate the unit on an electrical circuit of proper size.

8. Place black plastic condensate pan thru back or front.

- Make sure pads are installed upwards and drain hose is in pan.

CLEANING

1. CLEANING THE INTERIOR AND EXTERIOR

- The interior and exterior of the unit can be cleaned using warm water with soap.
- Do not use an abrasive cleaner because it will scratch the surface.

2. CLEANING THE CONDENSER FINS

- To maintain proper refrigeration performance, the Condenser coil must be free of dust, dirt, and grease.

It will require to clean it periodically. Condenser fins should be cleaned, at least every three months (90 days) or as needed.

3. CLEAN THE GASKET

- The door gasket should be cleaned frequently to maintain proper sealing. Use warm water and a mild soap.

4. CHECK AFTER CLEANING

- Check the unit again for safety.
- Check that the unit is operating properly.

CAUTION

1. POWER CORD

- Be sure the power cord is connected to the proper voltage.
- Compressor warranties are void if compressor burns out due to improper voltage.
- A protected circuit of the correct voltage and amperage must be run for connection of the line cord.
- Turn ' off ' the power switch before disconnecting the power cord whenever performing maintenance functions or cleaning the refrigerated cabinet.
- If the power cord of Refrigerator (Freezer) is damaged, it must be replaced by the manufacturer or service agent or a similarly qualified person in order to avoid a hazard.

2. RE-STARTING

- If disconnected, wait 5 minutes before re-starting.

BASIC OPERATION

MCR-23FD
MCR-49FD

REFRIGERATOR

1. Plug in and turn on the power switch located on the bottom of the top grill.
The Display panel will be lighted. The compressor will begin to run.
2. The default temperature setting is 35°F (+1 °C)
3. The compressor is automatically cycled by the electronic controller (PCB).
4. Temp. Control range 39°F ~ 28°F (+7°C ~ -3°C)
5. The interior light is activated by the door switch when the door is opened.
6. Evaporator fan motor(s) will run after all doors are completely closed.

DISPLAY PANEL

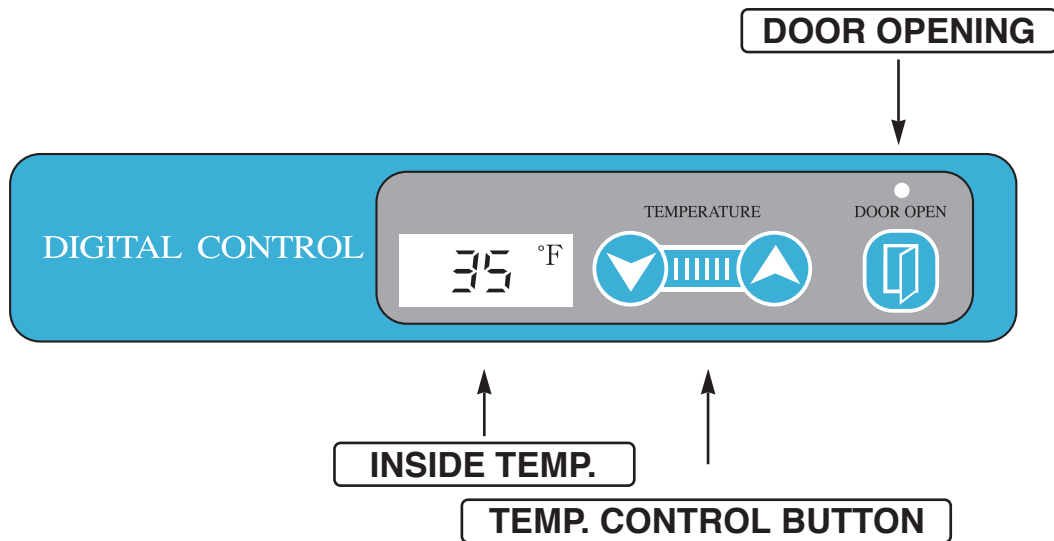

1. UP / DOWN BUTTON (Temperature control button)

- By pushing the up/down button, you can set the inside temperature.

2. DOOR OPENING INDICATOR

- If door is opened, door opening indicator will be turned on.
- If the door is left open for 5 minutes an alarm will sound continuously.
- The alarm will stop immediately upon closing the door.

BASIC OPERATION

MCF-23FD
MCF-49FD

FREEZER

1. Plug in and turn on the power switch located on the bottom of the top grill.
The Display panel will be lighted. The compressor will begin to run.
2. The default temperature setting is -2°F (-18°C)
3. The compressor is automatically cycled by the electronic controller (PCB, D-sensor).
4. The Defrost cycle is automatically controlled by the D-sensor and the PCB.
5. Temp. Control range 5°F ~ -9°F (-3°C ~ -24°C)
6. The interior light is activated by the door switch at the bottom of the grill when the door is opened.
7. Evaporator fan motor(s) will run after all doors are completely closed.

DISPLAY PANEL

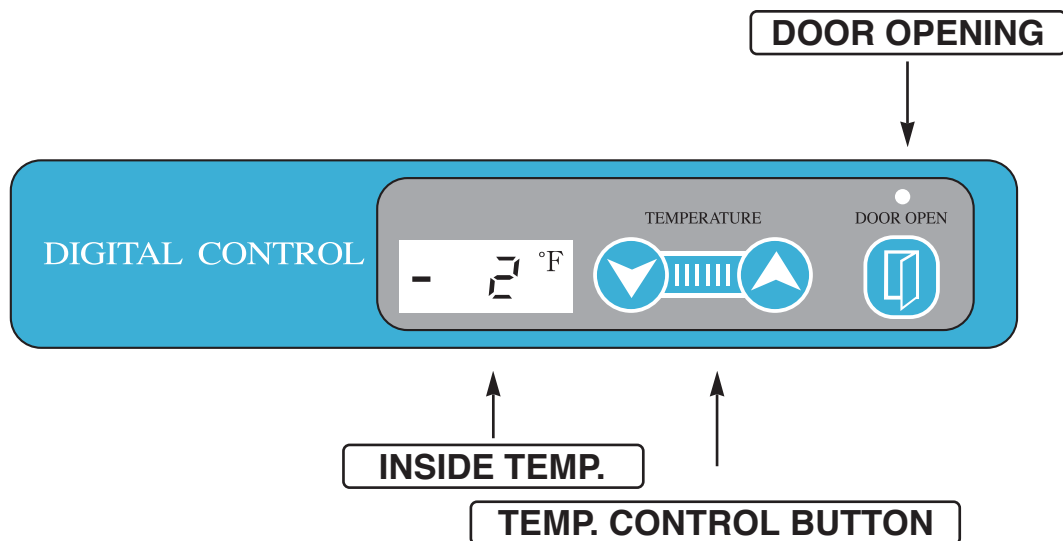

1. UP / DOWN BUTTON (Temperature control button)

- By pushing the up/down button, you can set the inside temperature.

2. DEFROST

- The electronic defrost controller is set at the factory to provide a defrost cycle every 6 hours.
- Once all frost is eliminated, the defrost control is changed to the freezer mode.
- The panel displays "dF" during the defrost.

3. DOOR OPENING INDICATOR

- If door is opened, door opening indicator will be turned on.
- If the door is left open for 5 minutes an alarm will sound continuously.
- The alarm will stop immediately upon closing the door.

REVERSIBLE-DOOR ASSEMBLY METHOD

MODEL : MCF-23FD / MCR-23FD

1. REMOVAL OF TOP GRILL and GRILL ASSEMBLY

- 1) Remove the TOP GRILL by removing securing screws. Upper or downward located ① in the PICTURE (A)

- 2) Remove GRILL by removing securing screws. connected Left and right side located ② in the PICTURE (A)

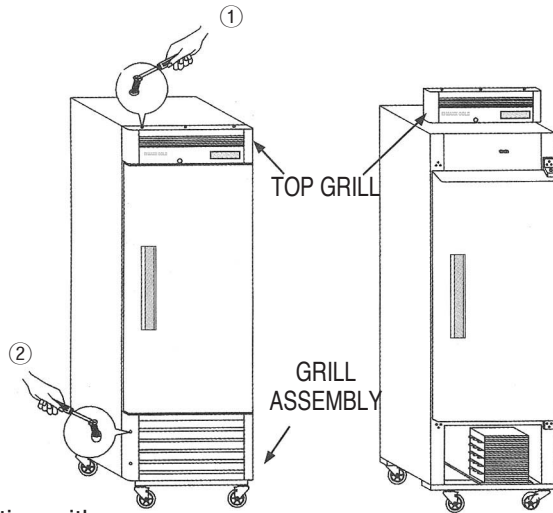

PICTURE A

Caution : Disconnect power before reversing door, use caution with cares associated with electronic control.

2. Taking apart of DOOR-ASSEMBLY

- 1) Follow steps ① ~ ⑩ in order at the PICTURE (B)

Caution : Door is heavy hinges are strong loaded. Use appropriate care when removing door.

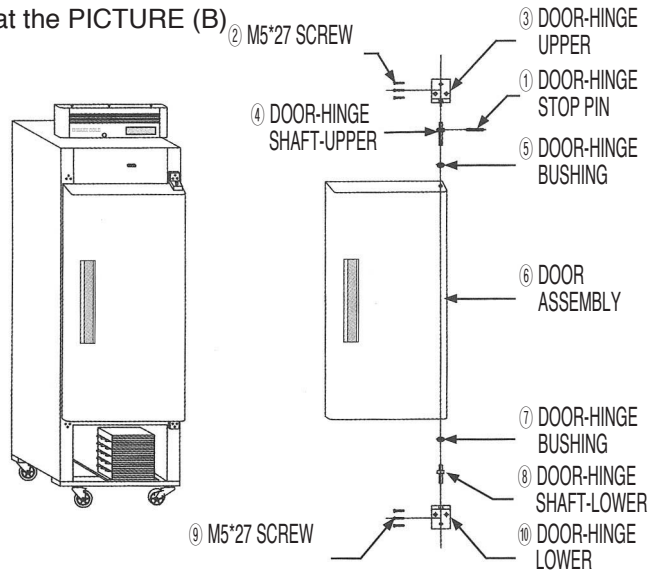

PICTURE B

3. Installation method of REVERSIBLE DOOR

- 1) After reversing 180 degree DOOR ASSEMBLY ⑥, locate the HANDLE in the desired side.
- 2) Assemble in the following order.

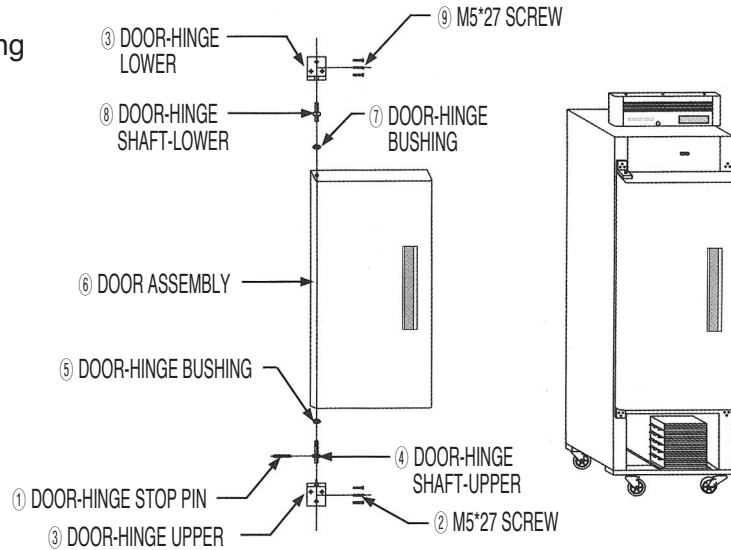

PICTURE C

- After assembling ③②, assemble ④⑤
 - Insert into ④ DOOR ASSEMBLY of ⑥
 - After inserting ⑦⑧, secure ③⑨
 - Insert reversible for suitable spring elasticity
- # Attention : Securely tighten all fasteners.

4. Installing TOP GRILL and GRILL ASSEMBLY

- 1) Install the screws at the location ① on the top and bottom of the top grill.
- 2) Install the screws at the location ② on the left and right side of the grill assembly.

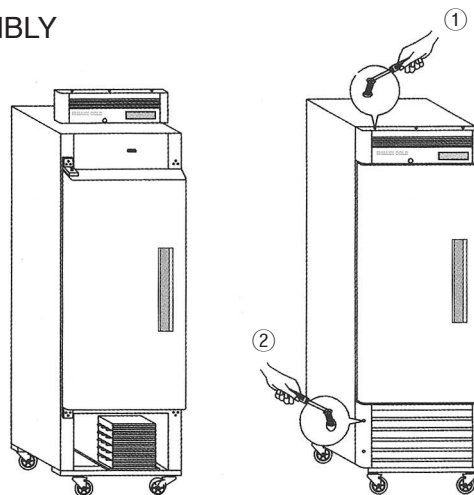

PICTURE D

TROUBLE SHOOTING GUIDE

SYMPTOMS	CAUSES	SOLUTIONS
Refrigerator/Freezer is freezing (thawing) food.	<ul style="list-style-type: none"> ● The Temp. is set too low (high) to maintain food freshness. 	<ul style="list-style-type: none"> ● Push the button to a warmer (colder) position.
The unit does not refrigerate at all.	<ul style="list-style-type: none"> ● There is a power connection failure problem. 	<ul style="list-style-type: none"> ● Check the power cord to make sure the unit is plugged in correctly.
The unit does not refrigerate well.	<ul style="list-style-type: none"> ● The unit is in sunlight or near a heating device. ● The unit contains hot food or too much food. ● The unit door is opened too frequently or left open too long. ● The temp. Is not set on the correct position. ● The condenser is clogged. 	<ul style="list-style-type: none"> ● Check the installation place. ● Check the condition of stored food. ● Check the position of the temperature setted. ● Clean condenser.
There is a loud noise.	<ul style="list-style-type: none"> ● The floor is too weak or the unit is not level. ● The back-side of the unit is too close to the wall. ● The tray is not in the correct position. 	<ul style="list-style-type: none"> ● Check the installation and adjust the tray position.
There is condensation in the unit exterior.	<ul style="list-style-type: none"> ● High-moisture air can produce dew-drops during high condensation humidity. 	<ul style="list-style-type: none"> ● Wipe with a dry cloth.
There is condensation the unit interior.	<ul style="list-style-type: none"> ● The door is opened too frequently or left open too long. ● Damp food is stored. 	<ul style="list-style-type: none"> ● Keep the door closed to remove condensation.
The door does not close tightly.	<ul style="list-style-type: none"> ● The door is bent. ● The door gasket has come out. ● The unit is not level. 	<ul style="list-style-type: none"> ● Reposition the gasket. ● Level the unit again.

MEMO

MEMO

MEMO



3355 Enterprise Ave. Suite 160
Ft. Lauderdale, FL 33331
Tel: (954) 202-7419
Fax: (954) 202-7337
www.asburyfoodservice.com

■ **WARRANTY AND TECHNICAL SERVICE**

Warranty and Service Parts
Toll free: 1-888-464-WASP
Fax: 414-774-2410
24 hours a day, 7 days a week