

Undercounter Refrigerator Manual

Model – MCR27U

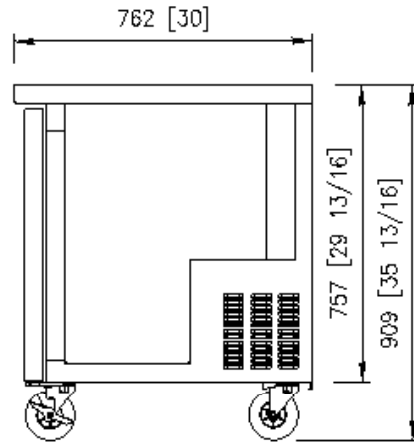
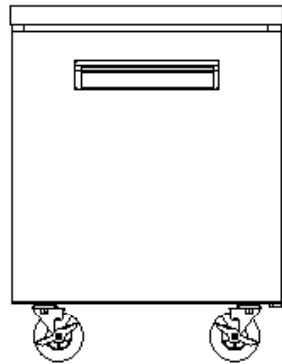
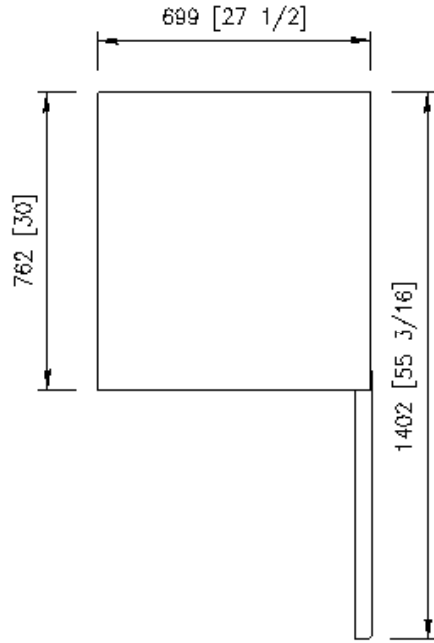

1. Technical Specifications		
Amp	115V	3.2A
Connection		15 amp plug
Refrigerant	Name	R134a
	Q'ty (oz)	2.5
	Q'ty (gram)	70
Compressor	HP	1/5 HP
	Samsung	SD162C-L1U2
2. Function Specifications		
Temp Range	°F	32°F ~ 40°F
Capacity	Cubic Feet	7
Climate Class		N
Max Ambient Temp	°F	89.6°F
Min Ambient Temp	°F	59°F
Castors	5"	4EA
Shelves		2EA
Doors		1EA
Exterior Finish		Stainless Steel
Interior Finish		Stainless Steel
3. Sizes		
Exterior Dimensions	Width(Inches)	27 1/2 inch
	Depth (Inches)	30 inch
	Height (Inches)	35 13/16 inch
Weight	LBS	143 lb

Model – MCR36U

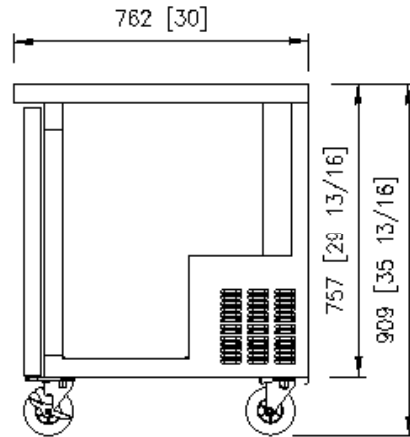
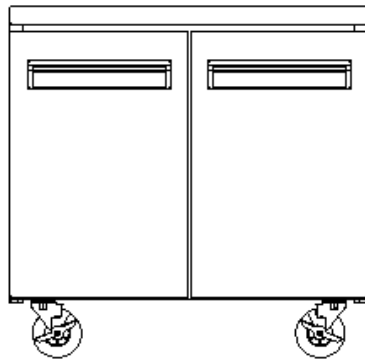
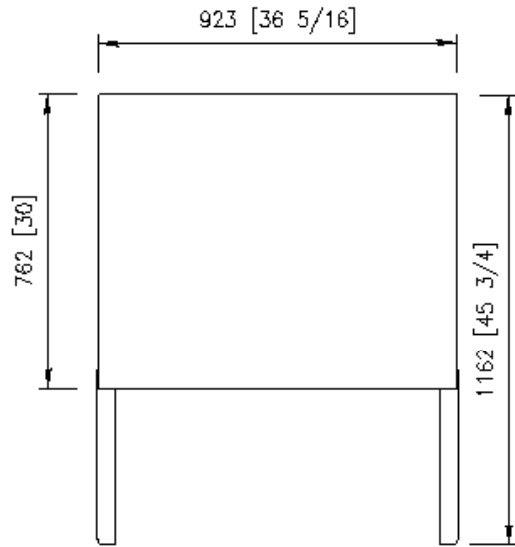

1. Technical Specifications

Amp	115V	3.2A
Connection		15 amp plug
Refrigerant	Name	R134a
	Q'ty (oz)	2.5
	Q'ty (gram)	70
	HP	1/5 HP
Compressor	Samsung	SD162C-L1U2

2. Function Specifications

Temp Range	°F	32°F ~ 40°F
Capacity	Cubic Feet	9
Climate Class		N
Max Ambient Temp	°F	89.6°F
Min Ambient Temp	°F	59°F
Castors	5"	4EA
Shelves		4EA
Doors		2EA
Exterior Finish		Stainless Steel
Interior Finish		Stainless Steel

3. Sizes

Exterior Dimensions	Width(Inches)	36 5/16inch
	Depth (Inches)	30 inch
	Height (Inches)	35 13/16 inch
	Weight	LBS 172 lb

Model – MCR48U

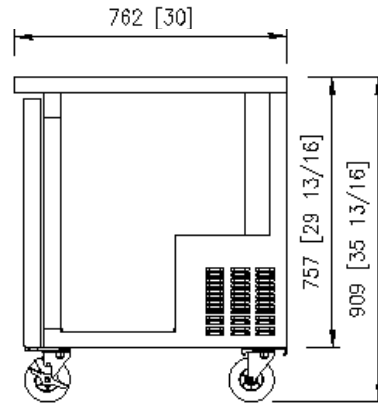
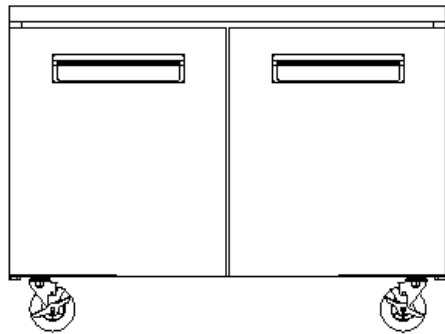
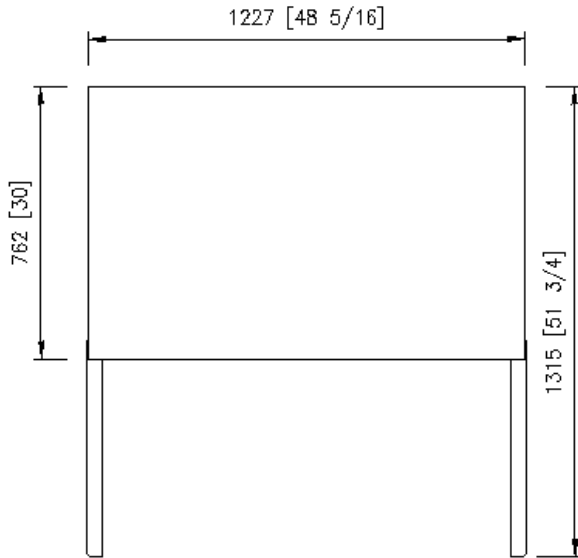

1. Technical Specifications		
Amp	115V	6.0A
Connection		15 amp plug
Refrigerant	Name	R134a
	Q'ty (oz)	3.5
	Q'ty (gram)	100
	HP	3/8 HP
Compressor	Samsung	SK1A1C-L2W
2. Function Specifications		
Temp Range	°F	32°F ~ 40°F
Capacity	Cubic Feet	12
Climate Class		N
Max Ambient Temp	°F	89.6°F
Min Ambient Temp	°F	59°F
Castors	5"	4EA
Shelves		4EA
Doors		2EA
Exterior Finish		Stainless Steel
Interior Finish		Stainless Steel
3. Sizes		
Exterior Dimensions	Width(Inches)	48 5/16 inch
	Depth (Inches)	30 inch
	Height (Inches)	35 13/16 inch
Weight	LBS	194 lb

Model – MCR60U

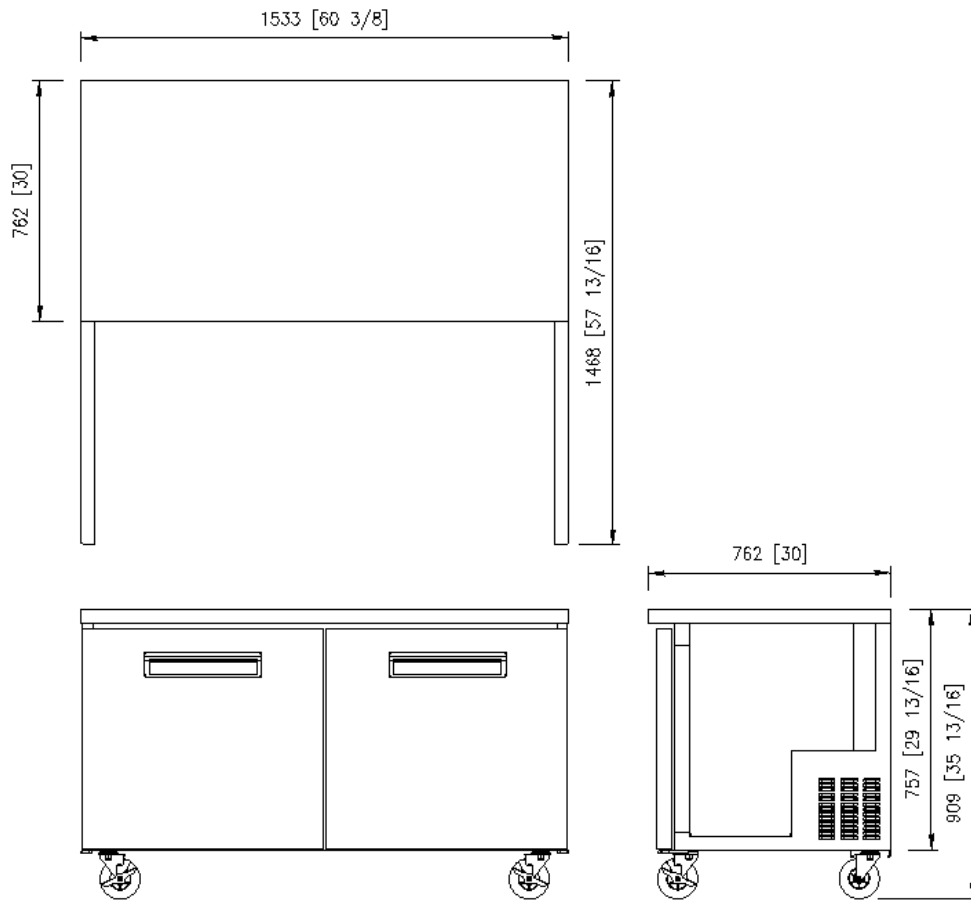

1. Technical Specifications		
Amp	115V	6.0A
Connection		15 amp plug
Refrigerant	Name	R134a
	Q'ty (oz)	3.5
	Q'ty (gram)	100
	HP	3/8 HP
Compressor	Samsung	SK1A1C-L2W
2. Function Specifications		
Temp Range	°F	32°F ~ 40°F
Capacity	Cubic Feet	16
Climate Class		N
Max Ambient Temp	°F	89.6°F
Min Ambient Temp	°F	59°F
Castors	5"	4EA
Shelves		4EA
Doors		2EA
Exterior Finish		Stainless Steel
Interior Finish		Stainless Steel
3. Sizes		
Exterior Dimensions	Width(Inches)	60 3/8inch
	Depth (Inches)	30 inch
	Height (Inches)	35 13/16 inch
Weight	LBS	236 lb

Model – MCR72U

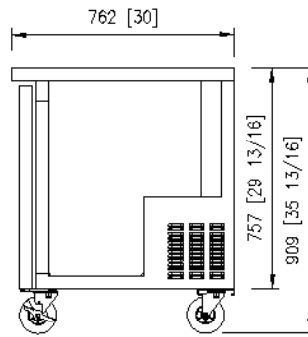
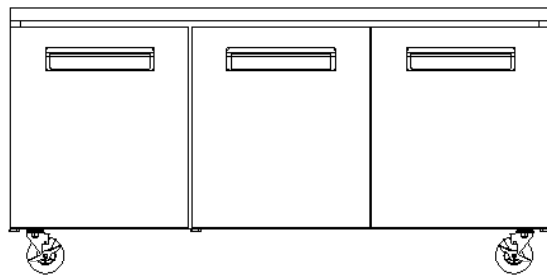
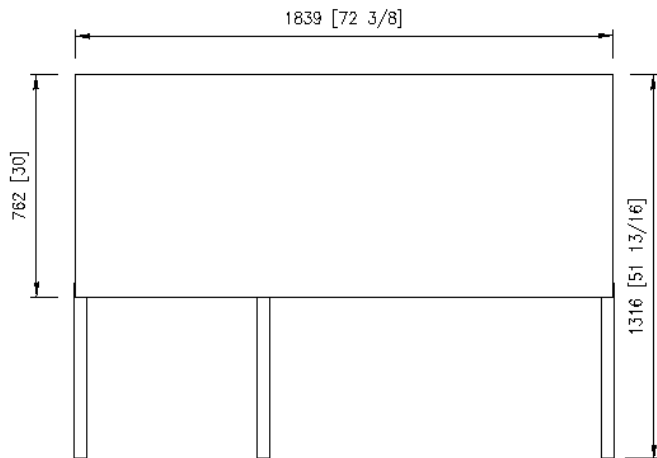

1. Technical Specifications

Amp	115V	6.1A
Connection		15 amp plug
Refrigerant	Name	R134a
	Q'ty (oz)	5.3
	Q'ty (gram)	150
	HP	3/8 HP
Compressor	Samsung	SK1A1C-L2W

2. Function Specifications

Temp Range	°F	32°F ~ 40°F
Capacity	Cubic Feet	20
Climate Class		N
Max Ambient Temp	°F	89.6°F
Min Ambient Temp	°F	59°F
Castors	5"	4EA
Shelves		6EA
Doors		3EA
Exterior Finish		Stainless Steel
Interior Finish		Stainless Steel

3. Sizes

Exterior Dimensions	Width(Inches)	72 3/8inch
	Depth (Inches)	30 inch
	Height (Inches)	35 13/16 inch
	Weight	LBS 269 lb

▣ Cabinet - 1

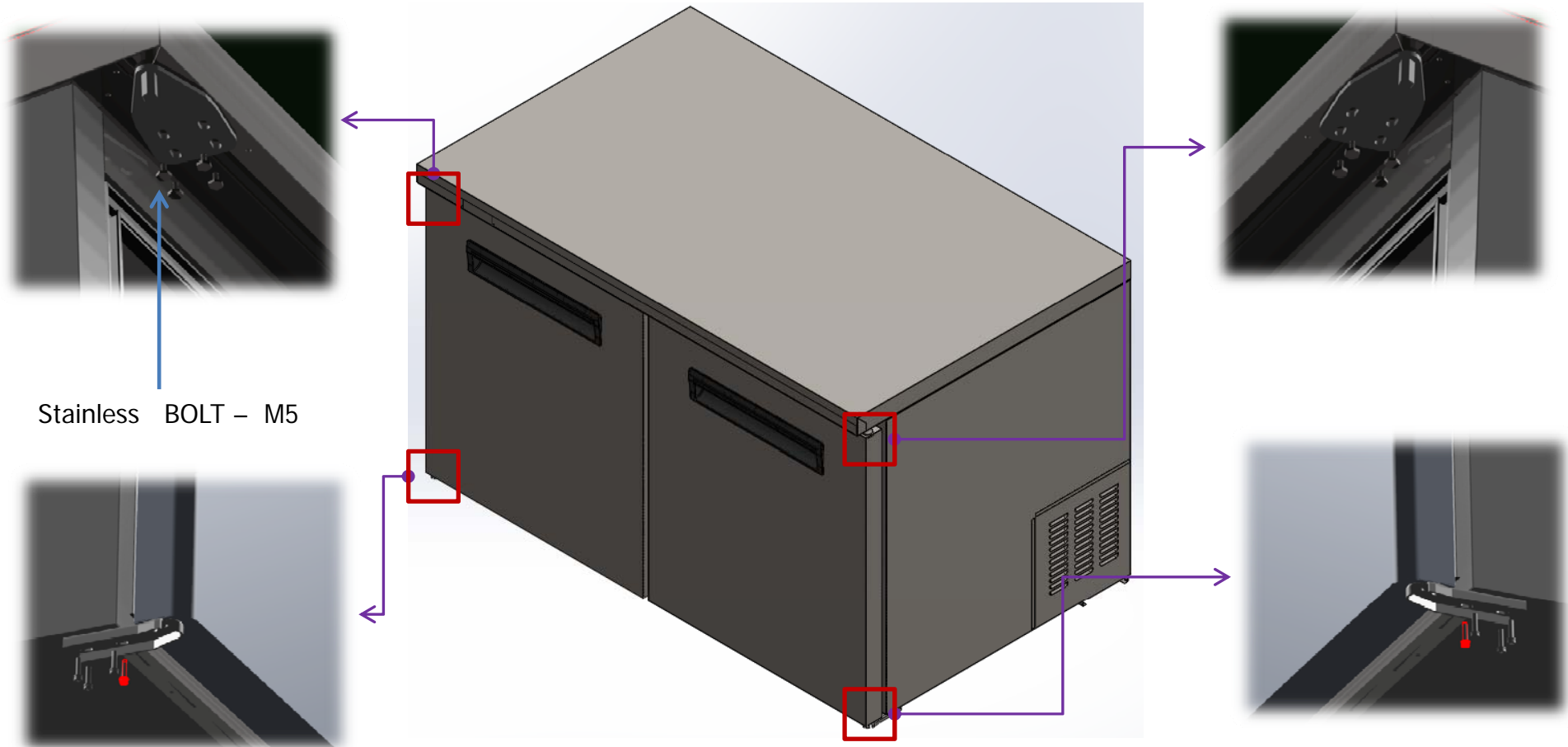

Stainless BOLT - M5

HINGE BOTTOM(LEFT) →



HINGE TOP ASSEMBLY



← HINGE BOTTOM(RIGHT)

DOOR

HINGE SHAFT



SPRING LEFT

DOOR GASKET

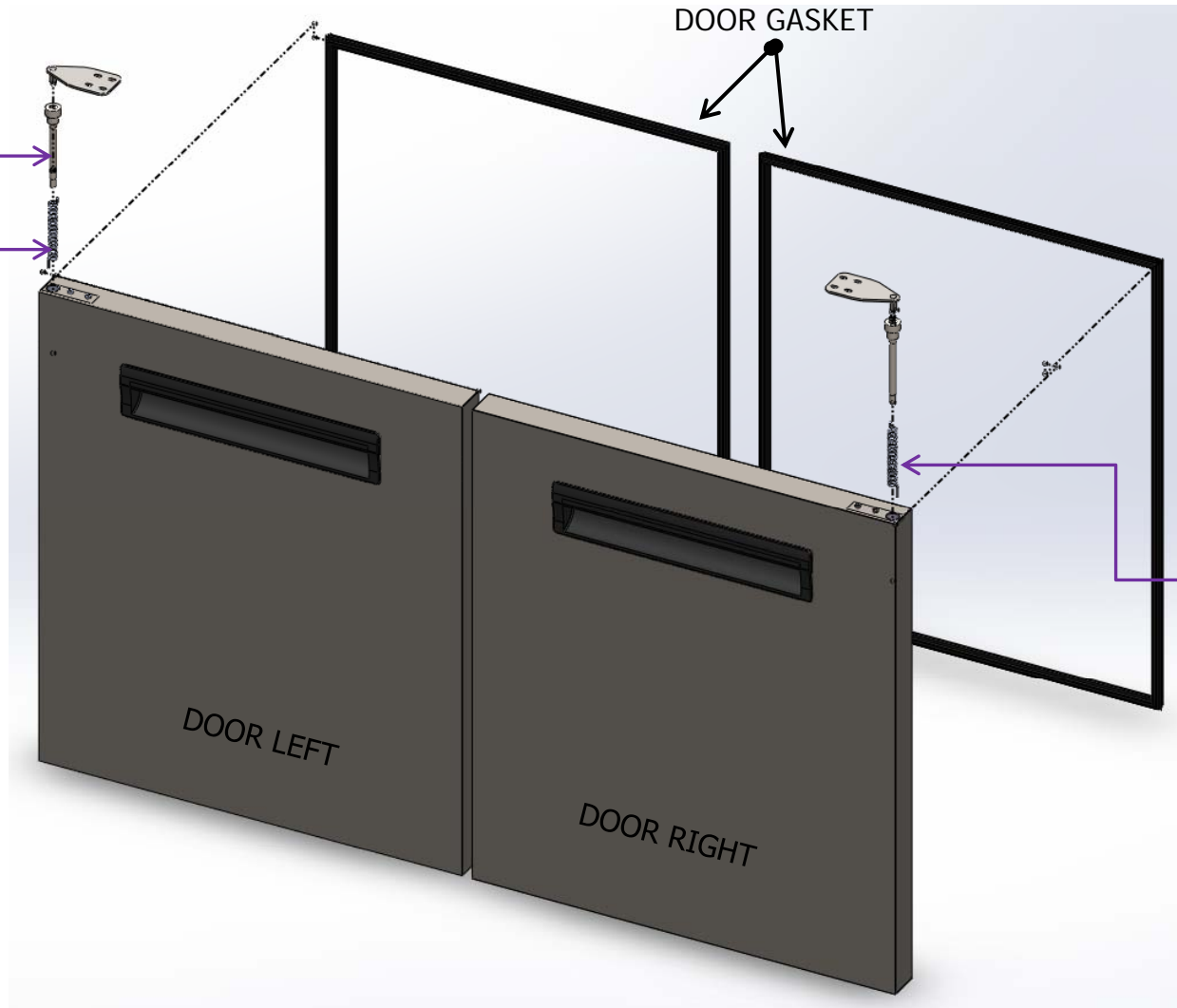

SPRING RIGHT

■ Cabinet - 2

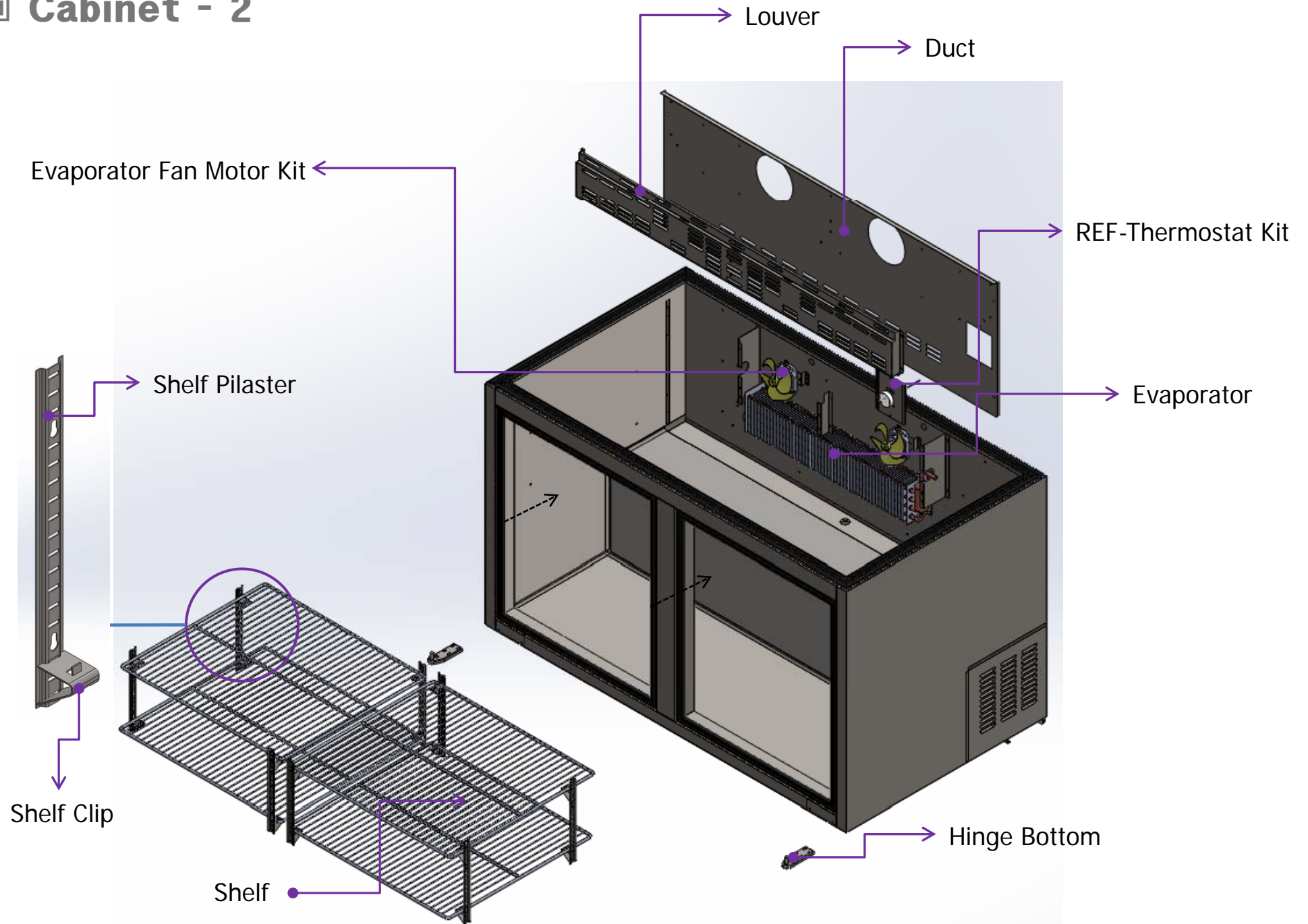

Machine room (Refrigeration)-1

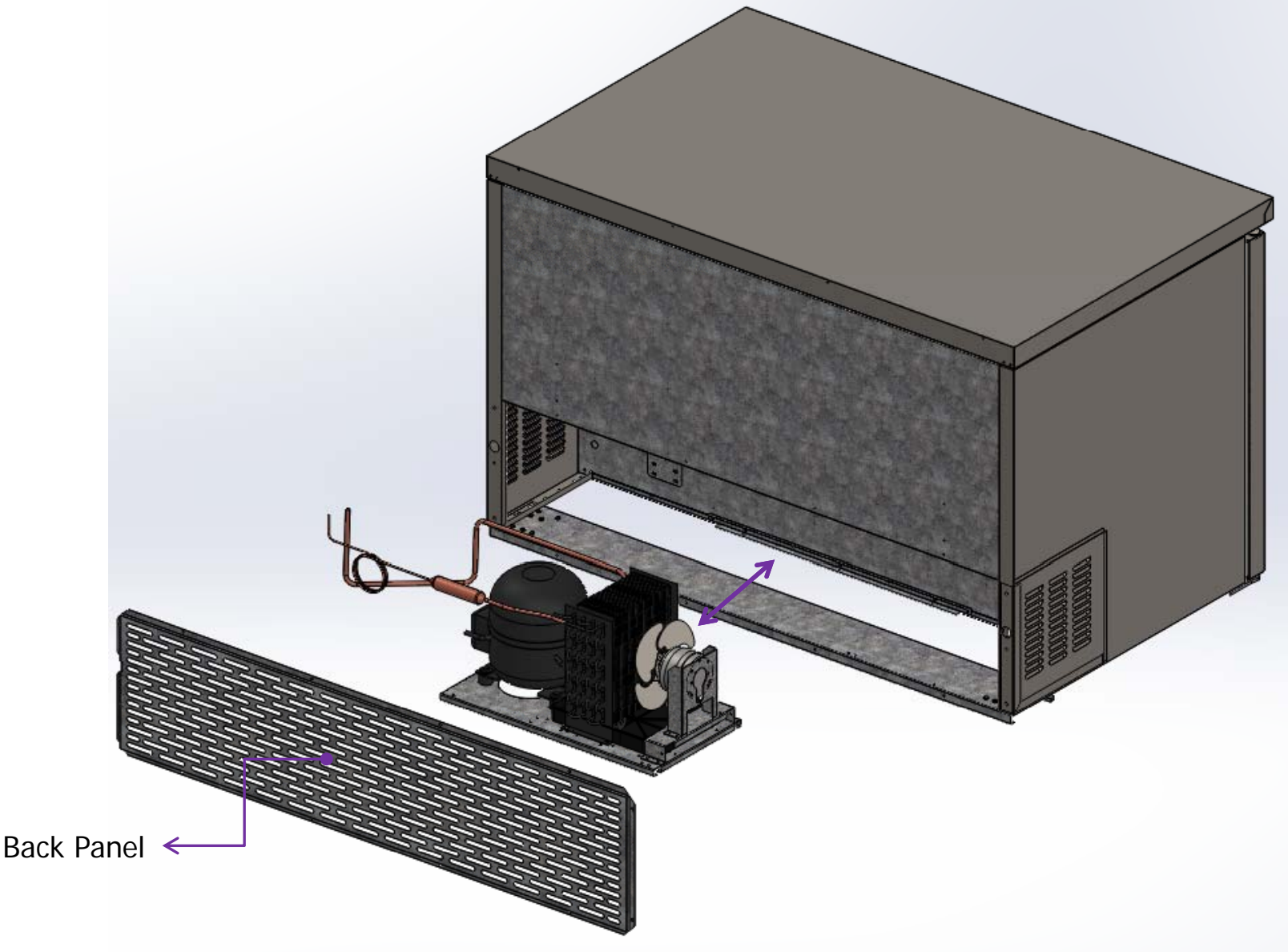

Machine room (Refrigeration)-2

Condensing Unit Disassembly - MCR27U / 36U / 48U / 60U / 72U

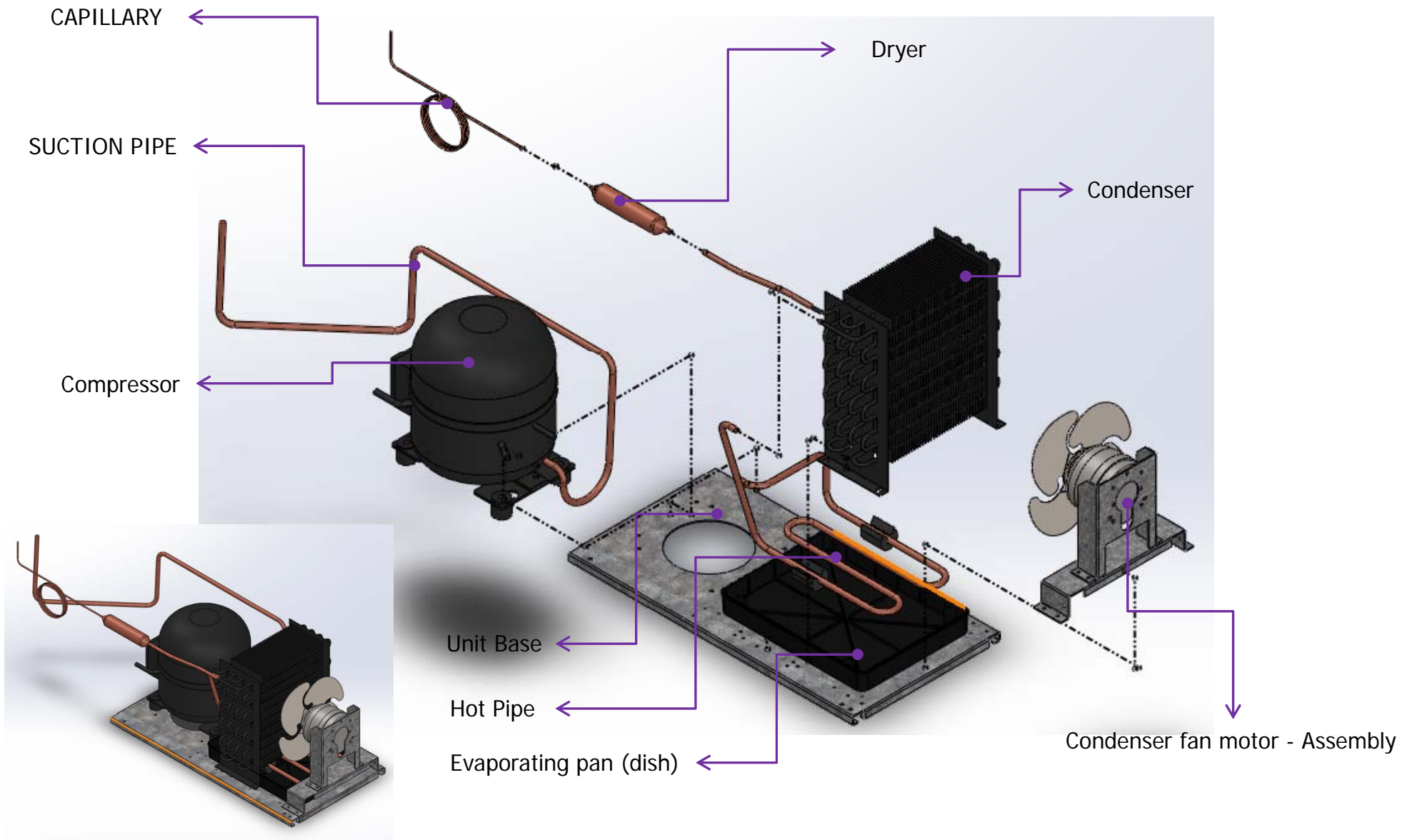

Compressor Wiring - SD162C-L1U [MCR27U, MCR36U]

Overload Protector
4TM427PHBY-53



PTC Relay -
J531Q33E100M200-2



Running Capacitor
250VAC-12 μ F

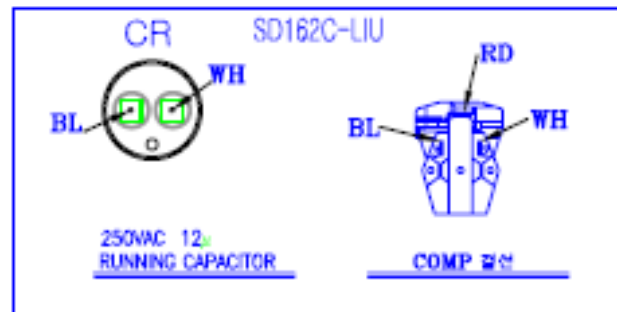
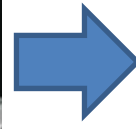

Compressor Wiring - SK1A1C-L2W [MCR48U, MCR60U, MCR72U]

Overload Protector
4TM795TFBZZ-53



PTC Relay -
J531Q34E220M350-3



Running Capacitor
250VAC-12 μ F
Starting Capacitor
125VAC-125 μ F

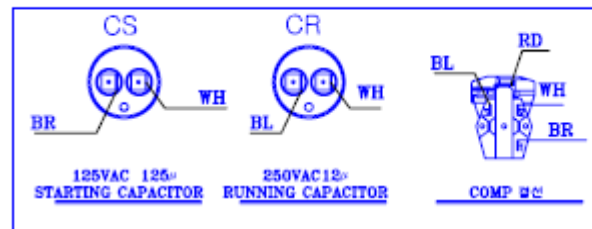
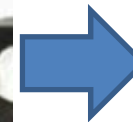
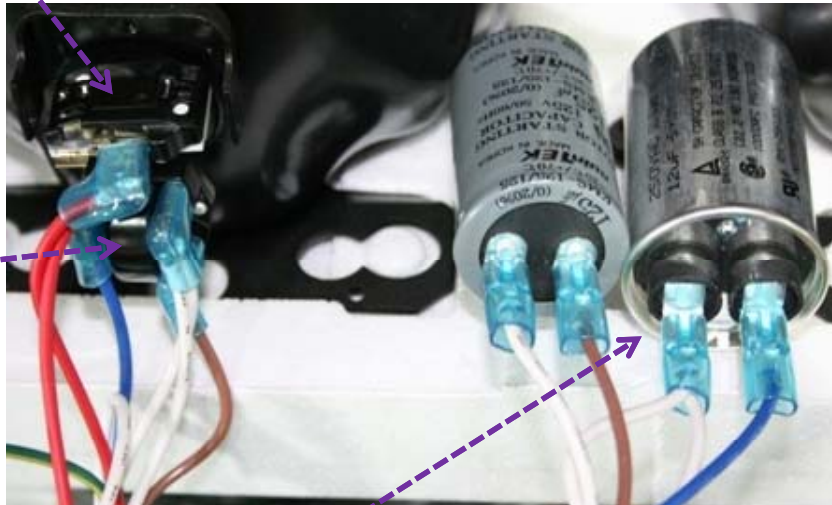

WIRE COLOR
WH : WHITE
BK : BLACK
RD : RED
BR : BROWN
BL : BLUE

■ Wiring Diagram
[MCR27U, MCR36U]

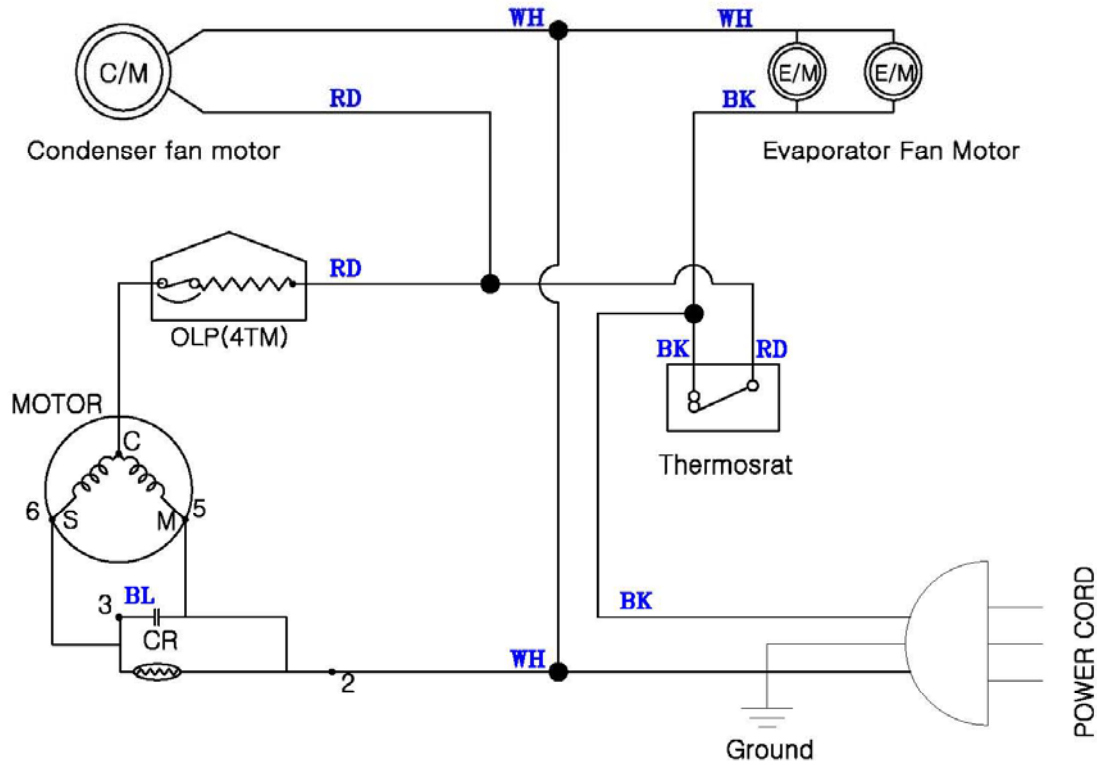

HARNESS COMP
Compressor Type [SD162C-L1U]



HARNESS MAIN



POWER CORD

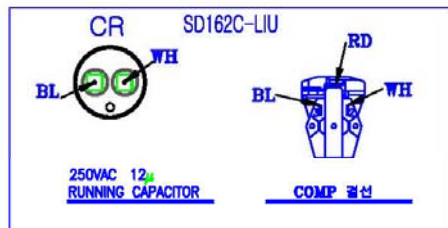

WIRE COLOR
WH : WHITE
BK : BLACK
RD : RED
BR : BROWN
BL : BLUE

■ Wiring Diagram
 [MCR48U, MCR60U, MCR72U]

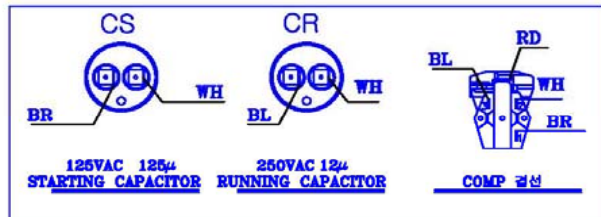
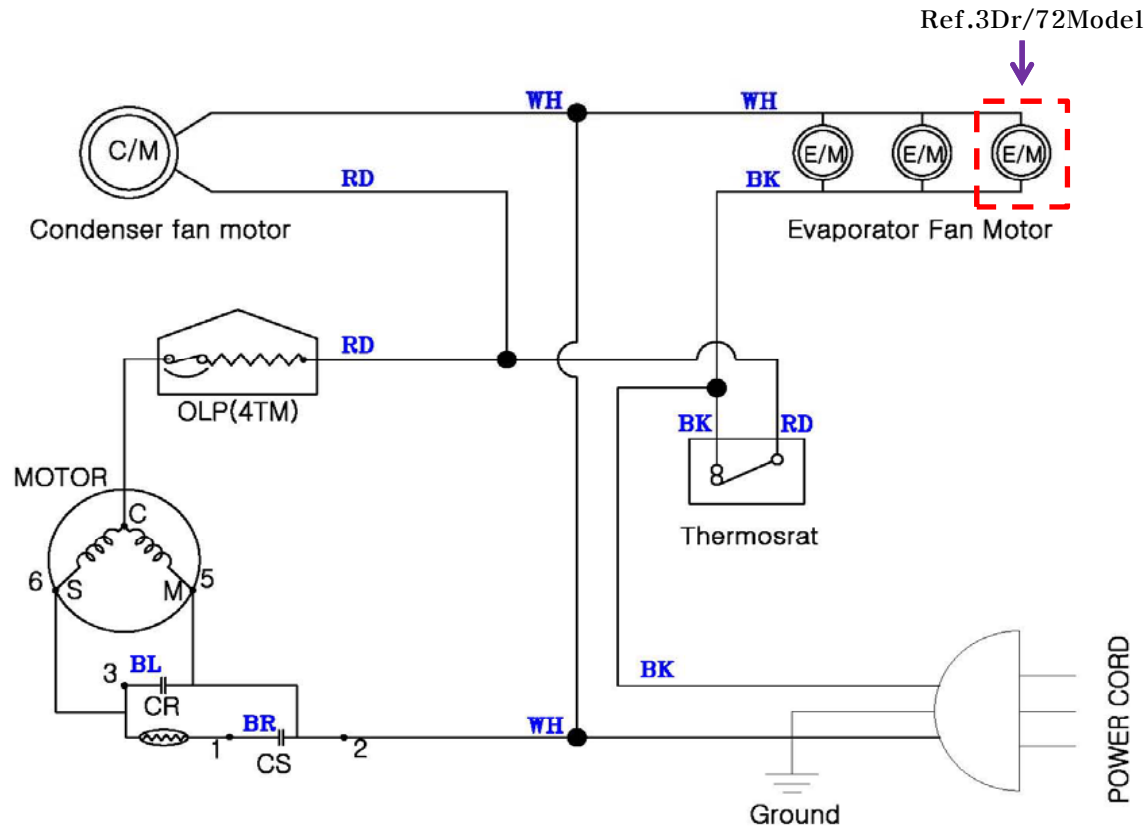

WIRE COLOR
 WH : WHITE
 BK : BLACK
 RD : RED
 BR : BROWN
 BL : BLUE

HARNESS COMP
 Compressor Type [[SK1A1C-L1U2]



HARNESS MAIN



POWER CORD

